

**Azland, Inc.**

# Defender 2+

**2 Box Seed Caddy**  
Integrated Work Platform  
Adjustable Poly Auger  
Tandem Axle Trailer  
Scale Ready

**Trailer**

21-1/2" Platform Height  
7k Torsion Axles  
Dual Axle Electric Brakes  
ST235/85R16 Tires  
2-5/16" Coupler  
Safety Chains  
Heavy Duty Jack  
Stop Turn Tail Lights

**Overall Dimensions**

Length: 227"  
Width: 101-3/8"  
Height: 140"

**Load Requirements**

Box Deck Height: 48-1/2"  
Minimum Lift Height 61"



Heavy Duty, Low Profile Design  
No Need To 'Shuttle' Auger From End To End

**Standard Equipment**

Heavy Duty Trailer Design  
Easy Glide Pro Box Placement  
13 HP Honda Motor With Electric Start  
Hydrostatic Driven Poly Auger  
Hydraulic Fold & Tilting Auger  
Clean Out At Auger Base  
Wireless Remote Control  
Powder Coat Paint Finish

**Optional Equipment**

4' Long Flexible Spout  
Dry Seed Treater  
Standard Or Premium Scales  
Scale Cover Security Box  
Metal Box Covers  
Tie Down Hooks  
Ramp Storage Brackets



Reversible Auger With  
Easy Cleanout At Auger Base



Scale Ready & Available With  
Dry And/Or Liquid Seed Treaters



Multi Use Platform Can Be Used For Hauling  
Toolboxes, Equipment, Seed, ATVs, or Fuel.

**Easily  
Fills Air Seeders!**



Shown With FC300SS, 300 Gallon Fuel Caddy  
Allows Filling Fuel And Seed At The Same Time  
Fuel Caddy Can Easily Be Unbolted And  
Placed In A Pickup For Harvest



# Defender 2+ Seed Caddy

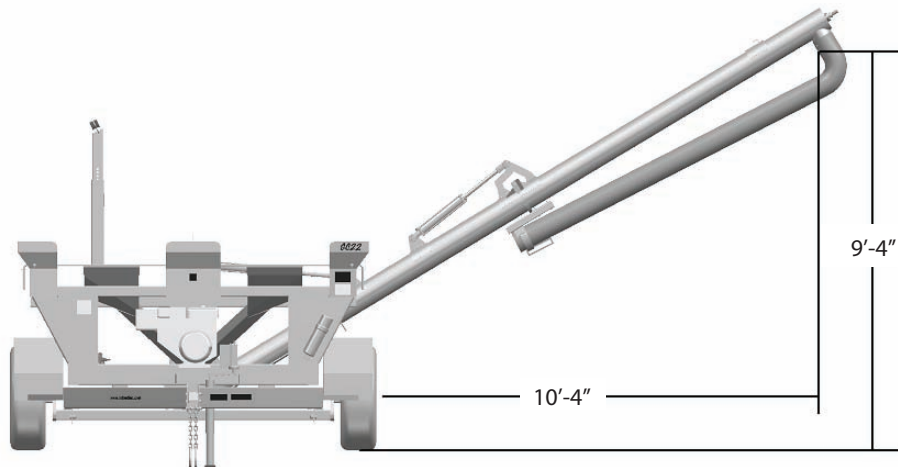

Auger Fully Extended For Maximum Reach

**All Seed Caddys Are Seed Treater Ready!**

**All Seed Caddys Are Scale Ready!**

**Adding Scales To Your Seed Caddy Does NOT Raise Your Unit Height!**

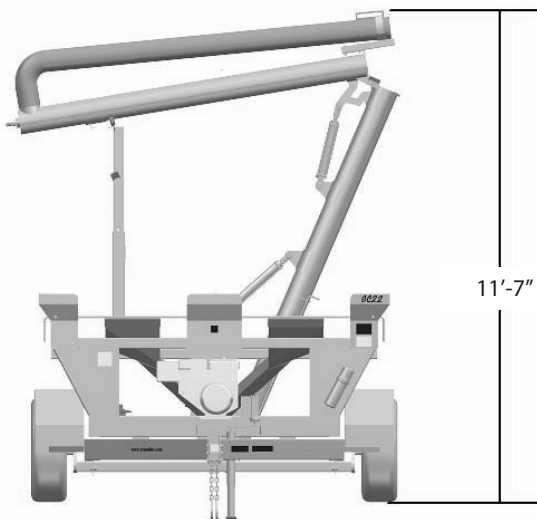

Transport - Maximum Height

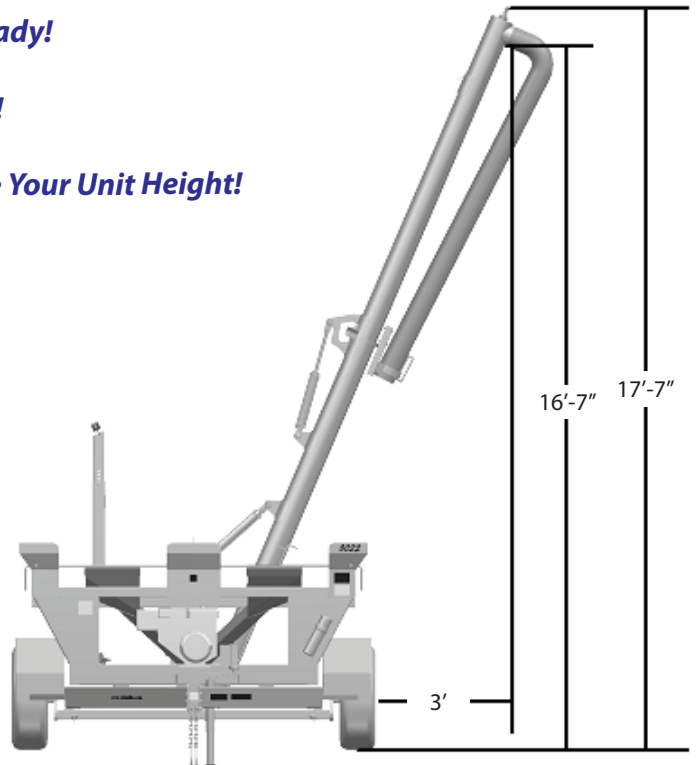

Auger Fully Extended For Maximum Height

**All Dimensions Are The Same With or Without Scales**

---

## Azland, Inc.

---

**Authorized Dealer**

345 Burnett Road, West Lafayette, IN 47906  
Phone: (765) 429-6200 Fax: (765) 742-4211  
www.azlandinc.com sales@azlandinc.com